

Agitators HAC Series

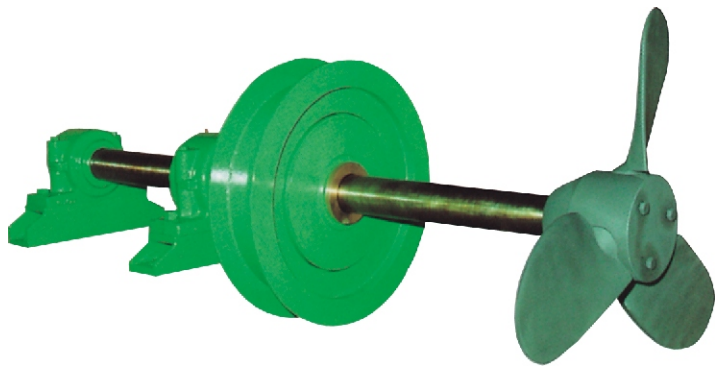

The HAC agitators, with a cantilever installation concept, are equipments with high mechanical rugged and flexible design. They can be installed in both concrete or metallic tanks resulting in a high efficiency set for the stock preparation.

Due to the special impeller design the HAC agitators have a high agitation capacity with low energy consumption and can be applied for consistencies up to 4,5% in vertical tanks and 5,5% in horizontal tanks.

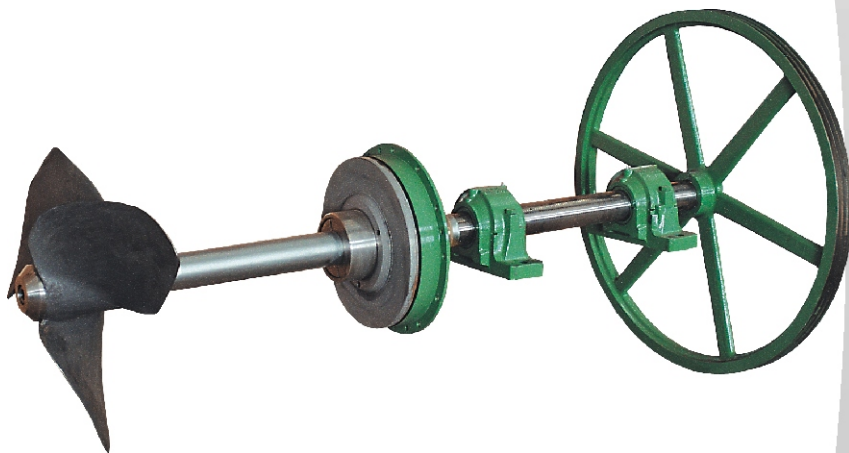

- The impellers are cast stainless steel built and their blades might be fixed or movable depending on the application.
- The impeller shafts have a chrome cover on the regions in direct contact to the paper stock.
- Gasket seals.
- High capacity bearing housings with an easy access for maintenance.
- It is "V" belt and pulleys driven.



Technical Features

Impeller diameter	mm	500	600	750	850	1100	1200	1350	1520
Horizontal tank - 1	m ³	50	100	150	260	350	480	550	650
Storage vertical tank - 2	m ³	10	15	25	40	60	80	110	155
Blend vertical tank - 2	m ³	7	12	20	30	45	60	80	115

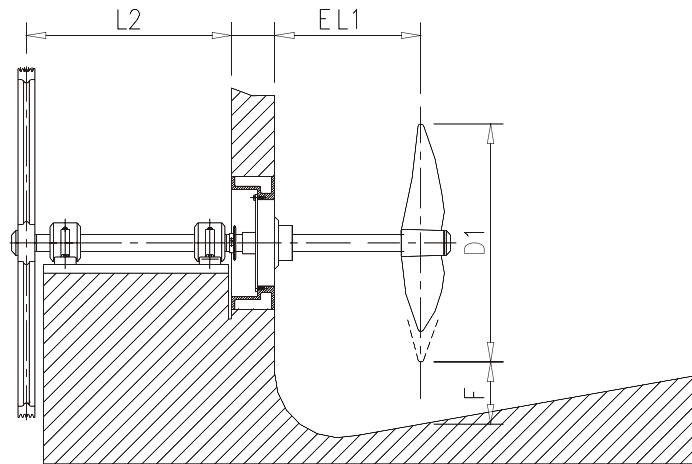

Power Requirements

Tank - 1	KW/hp	6/8	9/12	11/14,7	16/21,4	25/33,5	33/44,2	46/61,7	60/80,4
Tank - 2	KW/hp	3/4	4/5,4	6/8	8/10,7	12/16,1	15/20,1	20/26,8	27/36,2

Power Rating

Tank - 1	KW/hp	11/15	15/20,1	15/20,1	22/30	30/40	37/50	55/75	55/75
Tank - 2	KW/hp	5,5/7,5	7,5/10	11/15	15/20	18,5/25	22/30	30/40	37/50

Impeller Speed

Tank - 1	1/min	400	345	240	220	190	165	140	115
Tank - 2	1/min	320	270	210	190	160	140	120	110

Working Consistencies

Tank - 1 Dry	% bd	4 - 6	4 - 6	4 - 6	4 - 6	4 - 6	4 - 6	4 - 6	4 - 6
Tank - 2 Dry	% bd	4 - 5	4 - 5	4 - 5	4 - 5	4 - 5	4 - 5	4 - 5	4 - 5

Main Dimensions

D1	mm	500	600	750	850	1100	1200	1350	1520
L1	mm	700	700	700	700	900	900	900	1000
L2	mm	990	990	990	990	1120	1120	1200	1200
E	mm	200	200	200	200	200	200	200	200
F	mm	260	260	260	260	260	260	260	260

All data can be changed without any prior notice.



HERGEN S/A - Máquinas e Equipamentos
 Av. 7 de Setembro, 251 - Caixa postal 352
 89160-000 - Rio do Sul - Santa Catarina - Brasil
 Fone: 55 47 3531 4400 - Fax: 55 47 3531 4411
 www.hergen.com.br - e-mail: hergen@hergen.com.br